



Discovery Sounder Base

FUNCTION

The Discovery® Sounder Base is a multifunctional device comprising a mounting base for Discovery fire detectors, a sounder and a short-circuit isolator.

APPLICATION

The Discovery Sounder Base is used to provide audible warning of fire and is controlled by the fire control panel by means of the Discovery protocol. The particular features of this base are available only when it is being controlled by the full Discovery protocol with the panel programmed accordingly. Information on features should be requested from the panel manufacturer.

The Discovery Sounder Base can be used with a detector fitted or with a cap for operation as a stand-alone alarm device.

FEATURES

The product offers:

- 15 evacuation tones + 15 secondary or alert tones
- 7 volume levels
- Software-defined grouping addressing
- Unique acoustic self test
- Alarm switching by individual device, by group or of all devices on loop
- Set-up and testing of devices at point of installation
- Complies with NEN2575, DIN33404 and DIN0833
- Built in isolator with status information



Part no 45681-702 - Discovery Sounder Base



INVESTOR IN PEOPLE

A HALMA COMPANY



Assessed to ISO 9001:2008
LPCB Cert No. 010



Certificate No. 010
See www.RedBookLive.com



Assessed to ISO 14001:2004
Certificate number EMS 010

© Apollo Fire Detectors Limited 2014

36 Brookside Road, Havant,
Hampshire, PO9 1JR, UK.

Tel: +44 (0)23 9249 2412
Fax: +44 (0)23 9249 2754

Overseas offices: America China Germany

CE
0832

Email: sales@apollo-fire.com
Web: www.apollo-fire.co.uk

CONSULTANT'S SPECIFICATION

The Sounder Base shall be an Apollo Discovery Sounder Base with 15 selectable tone pairs and 7 volume settings and connected to a loop of fire detection and alarm devices controlled by a panel using the Apollo Discovery protocol.

The Discovery Sounder Base shall be synchronised by polling a synchronising address.

THE ADVANTAGES OF THE SOUNDER BASE

The right tone for your installation

The Discovery Sounder Base offers a choice of 15 evacuation tones, including the standard Apollo evacuation tone. One of these tones is selected during commissioning in order to suit local regulations or customs. The tones include those required by Dutch, Swedish, German, Australian, New Zealand and North American standards as well as the UK.

Whichever evacuation tone is selected there is a secondary tone which may be used for alerting or warning of a possible evacuation.

The right level of sound

The sounder is set during commissioning to one of 7 levels of sound, the highest level being nominally 90dB(A). At 60dB(A) the lowest level falls outside the scope of the standard, EN54. It has been included to provide a very local warning for the use of personnel in particular environments, such as nurse stations.

Flexibility of group addressing

In many installations a fire alarm must be raised by switching more than one sounder to alert or alarm simultaneously. This is achieved with Discovery Sounder Bases by assigning devices to groups on commissioning, with the group information being stored in each device. One command will then switch all devices in the group.

Location-specific volume setting

The Discovery Sounder Base volume can be configured at the point of installation.

The commissioning engineer simply sets the control panel to 'Setup' and then walks from one device to the next to set the required volume, using a magnetic wand (part no 29650-001). When all devices have been set the control panel is used to register all the individual volume settings.

TECHNICAL DATA

Operating voltage (polarity sensitive)	17-28V DC
Protocol pulses	5-9V
Current consumption at 24VDC	
Switch-on surge, <1s	1.2mA
Quiescent	370µA
Device operated at maximum volume	5.5mA
Maximum sound output at 90°	90±3dB(A)
Operating temperature	-20°C to +60°C
Humidity (no condensation)	0-95%
IP rating	21C
Nominal sounder output ±3dB(A) at 28V	
Level 1 (60dB(A))*	1mA
Level 2 (70dB(A))	1.3mA
Level 3 (74dB(A))	1.6mA
Level 4 (78dB(A))	2.1mA
Level 5 (82dB(A))	2.8mA
Level 6 (86dB(A))	4mA
Level 7 (90dB(A))	5.5mA
* Not EN54-3 compliant	

DIMENSIONS AND WEIGHT

Part no	Description	Dimension & Weight
45681-702	Discovery Sounder Base	115 x 38mm 140 g
45681-292	White Cap	100 x 9mm
45681-293	Red Cap	20g

PROTOCOL USAGE

The Discovery Sounder Base only operates with the Discovery protocol, for details please see below.

Output Bits	
2	Not Used
1	Sounder control
0	0=Alert, 1=Evacuate
Interrupt	No
Analogue Value	
1	Sounder failure
2	Not Used
3	Not Used
4	General fault
17 to 23	Quiescent, volume setting 1 to 7
Input Bits	
2	Not Used
1	Sounder status, 1=On
0	Confirmation of Alert (0), Evacuate (1)
Flag Setting	
XP95 Flag	Yes
Alarm Flag	No

DIMENSIONAL DRAWING

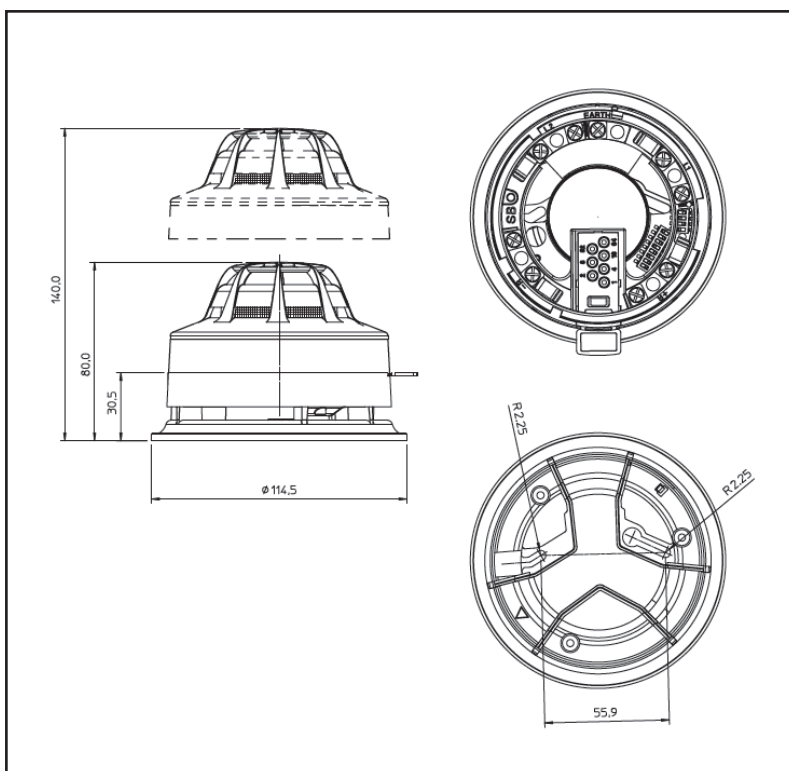

Byte Value	Primary Tone		Tone No.	Secondary Tone		Tone No.
1	Apollo Evacuation Tone *	567Hz for 0.5s, 850Hz for 0.5s	T1	Apollo Alert Tone*	1s off, 1s 850Hz	T0
2	Alternating - (Hochiki & Fullleon)*	925Hz for 0.25, 626Hz for 0.25s	T12	Continuous (Hochiki & Fullleon)*	925Hz	T11
3	Medium Sweep*	800Hz to 970Hz at 1 Hz	T14	Continuous	970Hz	T13
4	Fast Sweep	2500Hz - 2850Hz at 9Hz	T16	Continuous	2850Hz	T15
5	Dutch Slow Whoop (sweep) *	500 Hz - 1200Hz for 3.5s, 0.5s off	T3	Continuous*	850Hz	T2
6	DIN Tone (sweep) *	1200Hz - 500Hz for 1s	T4	Continuous*	850Hz	T2
7	Swedish Fire Tone*	660 Hz, 150ms on, 150ms off	T18	Swedish all clear signal-Continuous*	660Hz	T17
8	Aus (fast rise sweep)	3 x (500Hz - 1200Hz for 0.5s), 0.5s off	T6	Aus Alert Tone	420Hz, 0.625s, 0.625s off	T5
9	NZ (slow rise sweep)	500Hz - 1200Hz for 3.75s, 0.25s off	T7	NZ Alert Tone	420Hz, 0.625s, 0.625s off	T5
10	US Temporal LF (ISO 8201)	3 x (970Hz, 0.5s on, 0.5s off) 1s off	T19	Continuous	970Hz	T13
11	US Temporal HF (ISO 8201)	3 x (2850Hz, 0.5s on, 0.5s off) 1s off	T20	Continuous	2850Hz	T15
12	Simulated Bell - Continuous	Continuous	T8	Simulated Bell - Intermittent	1s off, 1s on	T9
13	Emergency Warning Siren	N/A	T10	Emergency Warning - All clear	N/A	T10
14	Evacuation Tone*	970Hz continuous	T13	Alert Tone	Silence for 1s, 970Hz for 1s	T19
15	Apollo Evacuation Tone *	567Hz for 0.5s, 850Hz for 0.5s	T1	Apollo Alert Tone	1s off, 1s 850Hz	T0

* EN54 Compliant

